



SUN ULTRA™ 40 M2 WORKSTATION ARCHITECTURE

Powerful and Expandable Technology for
Demanding Technical Applications

White Paper
January 2007

Table of Contents

Executive Summary	1
Powering Cutting Edge Science and Design	2
Complex and demanding workloads	2
The Sun Ultra 40 M2 Workstation	3
Professional Design Constraints	5
Sun Ultra 40 M2 Workstation Architectural Overview	8
Feature summary	8
The Next-Generation AMD Opteron 2200 Series processor	9
System-level architecture	10
Innovative 2D and 3D Graphics and Visualization	15
Sun Ultra 40 system bandwidth and expansion	15
Industry-leading NVIDIA graphics solutions	16
The Sun Visualization System	21
Operating Systems, Grid Software, and Development Tools	23
A choice of operating systems	23
Sun N1 Grid Engine software	25
Pre-installed Sun software development tools	26
Conclusion	28

Executive Summary

Cutting edge science, engineering, and design requires cutting edge tools. From electronic and mechanical design to energy development, biosciences, and scientific research, professionals and scientists need workstation technology that lets them think about problems in new ways. Key productivity for these professionals involves interactively exploring, evaluating, visualizing, and testing increasingly complex and critical designs and datasets — tasks that require not just computational horsepower, but balanced system architecture that provides the flexibility to ask and answer new questions. Whether expressing their unique vision or pushing the frontiers of science, technical professionals need the latest available workstation technology, and the highest quality, highest-performing tools available.

Unfortunately, while many have attempted to cast over-configured PCs in traditional workstation roles, the results have frequently fallen short. Ultimately, PC architectures often fail through inadequate processing capabilities, inherent system bottlenecks, and unbalanced I/O configurations. While these improvised systems may look like engineering or scientific workstations, they usually don't provide the quality, uniformity, and fundamental performance characteristics required to drive large applications and complex designs. Beyond initial system cost, the real price can be lost productivity for key technical design personnel, less effective and competitive designs, and missed market or scientific opportunities.

With 24 years of experience designing and building technical workstations for the enterprise, Sun understands the demanding requirements of catering to technical professionals. With its Sun Ultra™ 40 M2 and Sun Ultra 20 M2 workstations based on the AMD Opteron™ processor, Sun brings this strong legacy of design expertise to the x64 marketplace. The Sun Ultra 40 M2 workstation provides a powerful, innovative, and balanced workstation design that takes advantage of Next-Generation AMD Opteron 2200 Series processors, offers large memory capacity, and provides twice the storage capacity and graphics card support of the previous-generation Sun Ultra 40 workstation.

This document details the properties and architectural characteristics of the Sun Ultra 40 M2 workstation that make it ideal for demanding design, simulation, and visualization environments and applications.

Chapter 1

Powering Cutting Edge Science and Design

Getting better answers more quickly has never been more important. Increasingly, the kinds of questions that can be asked is only limited by the imagination and the capabilities of the computing and visualization resources employed. Today's scientific, design, and engineering challenges are often accompanied by the need to:

- Store and manipulate extremely large models and datasets
- Explore and visualize large and complex natural or synthetic 3D environments or scrutinize very fine details in high resolution
- Simulate and verify designs from electronics, to crash simulation, to complex thermal and fluid dynamics problems.

Not only do these challenges need considerable computational performance but they require flexible and balanced workstation system architecture. More than a fast processor, systems must provide balance in their ability to deliver, process, and output data in ways that are interactive and easily understandable. Productivity for scientists, designers, and engineers is key, giving them the ability to ask more questions, gain more insights, and come to better and more informed conclusions.

Complex and demanding workloads

Along with consolidation in the industry, roles and responsibilities of engineers, scientists, and designers have changed as well. Formerly separate disciplines are merging, and collaboration between disparate organizations is increasing. Design engineers now often have overlapping responsibilities to test, debug, and evaluate their designs. Scientists increasingly benefit from collaboration and sharing of data. With dramatic growth in the size of projects and datasets, these professionals need truly capable and flexible systems that can support a range of demanding workloads — from design and testing to simulation and visualization.

- ***Energy development (oil and gas)***

Geoscientists need the ability to store, manipulate, and visualize large earth models and seismic datasets. Better understanding of geologic strata leads to better drilling decisions, maximized reservoir yields, and better capacity utilization of valuable fossil fuel reserves. Compute-intensive applications such as seismic data visualization and interpretation, terrain visualization, and reservoir engineering require the highest possible CPU performance coupled with the highest levels of 3D graphics performance.

- ***Electronic design automation (EDA)***

Like most organizations, electronic design firms are demanding more from their infrastructure in order to compete and succeed. Taking advantage of constant technological progress, the complexity of most integrated circuit (IC) design continues to increase dramatically. It is not uncommon to encounter designs that feature hundreds of millions of gates. The size and complexity of designs likewise drives simulation times. For instance, it takes considerably more time and resources to simulate a 500-million gate device than a 50-million gate device. Electronic designers need systems with high-performance processors, large low-latency memory, and scalable storage. Designers may need to run simulations locally, or interface with a compute grid or cluster to access more resources.

- ***Mechanical computer aided design (MCAD)***

Modern mechanical models continue to grow in both size and complexity as designers seek to learn as much as they can before going into production. Design itself is now subject to stringent demands for visual realism. Building a complete digital mock-up of a large complex design, such as an airplane or automobile, requires sophisticated hardware, software, and graphics capabilities for the creation, manipulation, and visualization of the 3D design. In fact, with multi-gigabyte datasets, many designs are now large enough to push the limits of the four gigabyte memory space available on 32-bit systems. This limitation can cause excessive memory paging and very poor performance when larger models contend with the operating system for memory resources. To evaluate and visualize their designs, engineers may also need to run mechanical computer aided engineering (MCAE) simulations or crash tests (locally or remotely) and may need sophisticated graphics capabilities to evaluate the appearance or behavior of a part under design.

- ***Research in science, education, defense, and the life sciences***

Researchers everywhere need high-performance processors and high-quality 3D graphics to let them see the information behind their data. Scientists and researchers need to see their data with refined clarity and definition — yielding new perspectives and insights into complex technical problems. Whether visualizing intricate molecular protein models, running compute-intensive simulations, or evaluating results from MCAE or computational fluid dynamics (CFD) simulations, researchers and scientists need powerful and expandable workstation technology.

The Sun Ultra™ 40 M2 Workstation

To address the needs of scientists, researchers, and technical professionals, Sun designed the Sun Ultra 40 M2 workstation (Figure 1) to be one of the most compelling and capable technical workstations in the industry. With a single architecture, the Sun

Ultra 40 M2 workstation supports both 32-bit and 64-bit operating systems and applications, offering a high degree of flexibility. The Sun Ultra 40 M2 workstation is ideal for the most demanding technical workloads, including those with significant computational, memory, storage, and graphics requirements.



Figure 1. With Sun's 24-inch LCD monitor and a wealth of available NVIDIA graphics solutions, the Sun Ultra 40 M2 Workstation can drive multiple displays for design and visualization systems

The latest in a long line of technical workstations, the Sun Ultra 40 M2 workstation provides a balanced system architecture that avoids bottlenecks, and provides features and technology that allow professionals to get more from their IT investments. Features of the Sun Ultra 40 M2 workstation include:

- One or two Next-Generation AMD Opteron 2200 Series processor technology (dual-core)
- Three HyperTransport links per CPU
- Up to 32 GB of ECC memory capacity and high-speed memory bandwidth
- Up to 4 terabytes of internal disk storage capacity, RAID 0, 1, 0+1, and 5
- A choice of operating systems (Solaris™ Operating System (OS), Red Hat Enterprise Linux (RHEL), SuSE Linux Enterprise Desktop 10, or Windows XP Professional)
- Industry-leading NVIDIA 2D and 3D graphics accelerators with support for NVIDIA Scalable Link Interface (SLI)
- A complete set of pre-installed professional development tools
- A license for Sun N1™ Grid Engine software
- Certification testing and driver optimization

Building on the solid foundation of the Sun Ultra 40 workstation, the Sun Ultra 40 M2 workstation provides an enhanced feature set, and complements the capabilities of the Sun Ultra 20 workstation (Table 1).

Table 1. Feature comparison of Sun Ultra 20 M2, Ultra 40, and Ultra 40 M2 workstations.

Features	Sun Ultra 20 M2 Workstation	Sun Ultra 40 Workstation	Sun Ultra 40 M2 Workstation
Processor Type	One dual-core AMD Opteron 1200 Series processor	One or two single- or dual-core AMD Opteron 200 Series processors	One or two dual-core AMD Opteron 2200 Series processors
Memory	Up to 8 GB, Unbuffered DDR2-667 DIMMs	Up to 32 GB, Registered DDR1-400 DIMMs	Up to 32 GB, Registered DDR2-667 DIMMs
Graphics Accelerators	ATI ES1000 (on-board) NVIDIA Quadro NVS 285 NVIDIA Quadro FX 560 NVIDIA Quadro FX 1500 NVIDIA Quadro FX 3500	NVIDIA Quadro NVS 285 NVIDIA Quadro FX 560 NVIDIA Quadro FX 1500 NVIDIA Quadro FX 3500 NVIDIA Quadro FX 5500	NVIDIA Quadro NVS 285 NVIDIA Quadro FX 560 NVIDIA Quadro FX 1500 NVIDIA Quadro FX 3500 NVIDIA Quadro FX 5500
Storage	Up to two SATA drives, 1 TB maximum	Up to four SATA drives, 2 TB maximum	Up to 8 SATA drives, 4 TB maximum Up to 8 SAS drives, 1.2 TB maximum ^a
Networking	Dual gigabit Ethernet	Dual gigabit Ethernet	Dual gigabit Ethernet
Audio	High Definition Audio 1.0	AC '97 (7.1 channel, S/PDIF)	Hi Definition Audio 1.0
PCI Express slots	1 full-length x16 slot 1 full-length x16 slot (x8) 1 full-length x1 slot	2 full-length x16 slots 2 full-length x4 slots	2 full-length x16 slots 2 full-length x16 slots (x8)
32-bit/33-MHz PCI slots	3 full-length slots	2 full-length slots	1 full-length slot
Validated operating systems	Solaris 10 6/06 and later RHEL WS 3 Update 7/later RHEL WS 4 Update 3/later SLES 9 SP3 and later MS Windows XP Professional (SP2 and later)	Solaris 10 1/06 and later RHEL WS 3 Update 6 or later RHEL WS 4 Update 2 or later SLES 9 SP3 or later Microsoft Windows XP Professional	Solaris 10 OS 6/06 and later RHEL WS 3 Update 8 or later RHEL WS 4 Update 4 or later SLED 10 or later MS Windows XP Professional (32-bit or x64 Edition) SP2 and later

a.SAS drives require a PCI Express controller card

Professional Design Constraints

More than low cost or even high-performance, Sun engineers its workstations to provide the advantages of balanced architecture. For the Sun Ultra 40 M2 and its other workstations, Sun also provides extensive ISV certification, driver optimization, and support to make sure that key applications are supported and work as expected. This comprehensive approach is keenly focused on the needs of designers, engineers, scientists, and other technical professionals that depend on Sun workstations, as well as the IT organizations that support them. The result is a variety of benefits for technical professionals:

- **Accelerate design cycles**

Faster design cycles require workstation technology that can handle challenging computational tasks and large datasets while retaining critical interactivity for user productivity. Each Sun Ultra 40 M2 workstation features the Next-Generation AMD Opteron 2200 Series processor, with dual cores and an integrated dual-channel memory controller to reduce latency and increase memory bandwidth. High-performance HyperTransport interconnects provide the lowest possible latency between the processor and the rest of the system. Each workstation

supports up to 32 GB of memory for large-memory applications and large data. Based on ECC-protected DDR2-667 memory DIMMs, the Sun Ultra 40 M2 workstation delivers over 10 GB per second of throughput between the processor and memory.

The Sun Ultra 40 M2 workstation also features high-density, high-performance, and highly-reliable internal storage. Utilizing serial ATA technology for density, the workstation accommodates up to eight internal 500GB drives for a maximum capacity of 4 TB. Utilizing RAID 0 for performance, and RAID 1 for redundancy, the Sun Ultra 40 M2 workstation can deliver very high transfer rates required to load the largest designs while safeguarding critical design data for mission-critical products and applications. Alternatively, up to eight high-speed SAS drives can be accommodated in the Sun Ultra 40 M2 chassis with a PCI Express controller card.

- ***Visualize more datasets, simultaneously***

With ever larger engineering datasets, it is increasingly important to be able to interactively visualize and collaborate. With four PCI-Express x16 (16-lane) expansion slots (two logically x16, two logically x8) the Sun Ultra 40 M2 workstation lets organizations deploy multiple high-performance 3D graphics solutions from NVIDIA. The result is greater interactivity, even with complex data, helping to inform insights and design decisions. A wide variety of NVIDIA Quadro NVS and FX graphics solutions are supported, providing acceleration for OpenGL visualization applications and support for multiple high-resolution displays.

Sun Ultra 40 M2 workstations can also be deployed as part of the Sun Visualization system¹, delivering scalable, sharable, and affordable immersive and remote visualization solutions. *Sun Scalable Visualization software* lets organizations deploy a cluster of supported systems for immersive environments or parallel rendering. Integrated with Sun N1 Grid Engine software, *Sun Shared Visualization software* lets users share an OpenGL application on a remote client while taking advantage of server-based hardware accelerated graphics. Each Sun Ultra 40 M2 workstation includes a Sun N1 Grid engine license, allowing both computational and graphical resources to be shared across the network.

- ***Develop quality software in less time***

Software developers can start developing Solaris and Java™ applications immediately after unpacking the system. Every Sun Ultra 40 M2 workstation ships with a licensed and pre-installed copy of the Solaris 10 OS, with innovative features such as Solaris Dynamic Tracing (DTrace), Predictive Self-Healing, Solaris Containers, and ZFS. DTrace provides real-time application debugging and optimization, giving programmers unprecedented observability into the system. Solaris Containers provides technology that allows a single Sun Ultra 40 M2 workstation to be divided into separate virtual instances of the Solaris OS, allowing for the development and testing of complex multi-system distributed applications on a single workstation.

1. As of this writing, the Sun Visualization System is in a technology preview stage.

A rich suite of Sun software development tools is also pre-installed on each Sun Ultra 40 M2 workstation. These intuitive, easy-to-use tools couple with the dual-core Next-Generation AMD Opteron 2200 Series processor for fast compile times, enabling the rapid development of web services as well as traditional applications. Pre-installed development tools include:

- Sun Studio Creator — a visual tool to help develop business-critical Java applications
- Sun Studio — a comprehensive, integrated suite of tools for enterprise C, C++, and FORTRAN applications
- Sun Java Studio Enterprise — a unified platform of tools, support, and services that are completely integrated with the Sun Java Enterprise System
- NetBeans™ IDE — comprehensive support for building IDE plug-in modules and rich client applications on the NetBeans platform.

- ***Deploy with confidence***

Technical workstations are often critical to the most important scientific and engineering projects. Sun's line of x64 workstation and server products help put the very latest technology in the hands of designers, engineers, and developers so that they can face their own challenges more effectively. At the same time, these systems greatly simplify deployment and maintenance for the IT organizations that support design and engineering professionals.

By using the same architecture to run 32-bit and 64-bit operating systems and applications, the Sun Ultra 40 M2 workstation helps customers protect their 32-bit investments while giving them a simplified migration path to 64-bit computing. To make sure that applications run as expected, Sun maintains strategic partnerships with leading ISVs to certify its workstations for compatibility with graphics accelerators and applications. Customers can take advantage of performance enhancements for 32-bit applications while retaining the ability to upgrade to 64-bit operating systems and applications when ready. In addition, each Sun workstation is supported by the power of the Sun Global Services Organization (GSO), providing a wide range of services to help customers migrate from legacy environments, reduce cost and complexity, accelerate network deployment, and deliver mobility with security — all from a single source.

While others cast less capable PCs as workstations, the Sun Ultra 40 M2 workstation is the result of a full Sun custom design. Beyond the capabilities and capacities of the workstation, the Sun custom motherboard form factor allows component placement for optimal airflow to ensure low component temperatures for high reliability, low acoustic noise, usability, and ruggedness. In fact, the Sun Ultra 40 M2 workstation is one of the quietest workstations available. The cooling system includes low-noise fans with fan speed controlled by monitoring multiple component temperatures. Structure-borne vibration and acoustic noise are also minimized by rigid chassis design and control of disk drive vibration.

Chapter 2

Sun Ultra 40 M2 Workstation Architectural Overview

The performance characteristics and broad applicability of the Sun Ultra 40 M2 workstation stem from the latest AMD Opteron processor technology and a robust physical architecture combined with proven software and graphics accelerator technology. The workstation allows users to take advantage of powerful NVIDIA graphics solutions (*chapter 3*), a broad choice of validated operating systems, and a full complement of pre-installed developer tools (*chapter 4*). The sections that follow detail the features and functionality of the Sun Ultra 40 M2 workstation.

Feature summary

Clean and careful integration has always been a hallmark of Sun system design, and the Sun Ultra 40 M2 workstation is no exception. The open workstation chassis is shown in Figure 2.

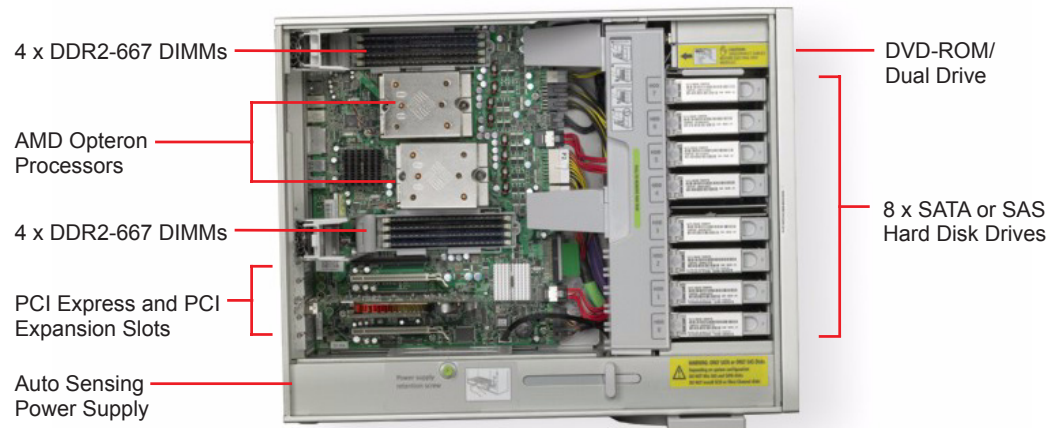

Figure 2. The Sun Ultra 40 M2 workstation chassis and motherboard

Each Sun Ultra 40 M2 workstation provides:

- One or two Next-Generation AMD Opteron 2200 Series processors (dual core) at a variety of available frequencies
- Up to 32 GB of ECC memory in 1 GB, 2 GB, or 4 GB DDR2-667 DIMMs
- Three HyperTransport 2.0 links per processor operating at up to 8 GB per second peak throughput
- Dual gigabit Ethernet ports integrated on the motherboard (RJ-45)
- DVD-ROM or DVD-Dual optical disk drives

- Up to eight 7200 rpm SATA disk drives (160, 250, and 500 GB 7200rpm drives, up to 4 TB maximum) with RAID 0, 1, 0+1, or 5
- Up to eight 15,000 rpm SAS disk drives (146 GB, up to 1168 GB maximum) with an additional PCI Express controller card (RAID 0, 1, or 1E)
- Two FireWire (IEEE 1394a) ports and eight USB 2.0 ports
- High Definition Audio (HDA 1.0, 10 ports)
- Four PCI Express slots (two physical x16 slots, x16 logically; two physical x16 slots, x8 logically)
- One full-length 32-bit/33-MHz PCI slot

The Next-Generation AMD Opteron 2200 Series processor

The Sun Ultra 40 M2 workstation employs Next-Generation AMD Opteron 2200 Series processors that extend the industry-leading performance trajectory established by first-generation AMD Opteron processors. A block-level diagram of the AMD Opteron 2200 Series processor is shown in Figure 3.

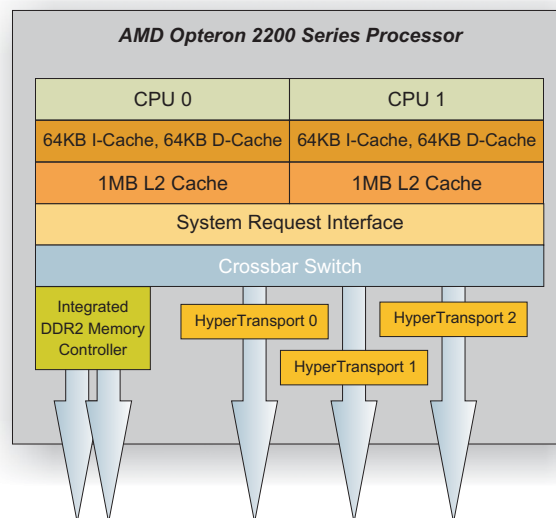

Figure 3. Block-level diagram of the Next-Generation AMD Opteron 2200 Series processor with dual cores and three HyperTransport links

The AMD Opteron processor extends the ubiquitous x86 architecture to accommodate x64 64-bit processing. Formerly known as x86-64, AMD's enhancements to the x86 architecture allow seamless migration to the superior performance of x64 64-bit technology. Unlike some x86/x64 processors, AMD Opteron processors are designed from the beginning to support multi-core architectures, with an integral crossbar switch and system request interface. In fact, the AMD Opteron 2200 Series processor is being launched only in dual-core configurations, and yet is able to retain the power envelope of previous generation AMD Opteron processors. This approach defines a new class of computing by combining full x86 compatibility, a high-performance 64-bit architecture, and the economics of an industry-standard processor.

Enhancements of the AMD Opteron processor over the legacy x86 architecture include:

- Sixteen 64-bit general-purpose integer registers that quadruple the general-purpose register space available to applications and device drivers as compared to x86 systems
- Sixteen 128-bit XMM registers for enhanced multimedia performance to double the register space of any current SSE/SSE2 implementation
- A full 64-bit virtual address space with 40 bits of physical memory addressing and 48 bits of virtual addressing that can support systems with up to 256 TB of physical memory
- Support for 64-bit operating systems to provide fully transparent and simultaneous 32-bit and 64-bit platform application multitasking
- A 128-bit wide, on-chip DDR2 memory controller that supports ECC and ChipKill technologies and provides low-latency memory bandwidth that scales as processors are added
- Virtualization support through an integrated hypervisor to aid with increasingly popular virtualization environments

Each processor core has a dedicated 1MB Level-2 cache, and both cores use the System Request Interface and Crossbar Switch to share the Memory Controller and access the HyperTransport links. This sharing represents an effective approach since performance characterizations of single-core based systems have revealed that the memory and HyperTransport bandwidths are typically under-utilized, even while running high-end server workloads.

System-level architecture

Figure 4 illustrates a logical block diagram of the Sun Ultra 40 M2 workstation motherboard and its integral set of HyperTransport connections between AMD Opteron processors and key NVIDIA I/O chipsets. Unlike legacy front-side bus architectures, the AMD Opteron processor with integrated fifth-generation HyperTransport technology links provides a scalable bandwidth interconnect between the processor and the I/O subsystem. HyperTransport technology interconnects help increase overall system performance by removing I/O bottlenecks and efficiently integrating with legacy busses, increasing bandwidth and speed, and reducing processor latency. At 16 x 16 bits and 1 GHz operation, HyperTransport technology provides support for up to 8 GB/s bandwidth per link.

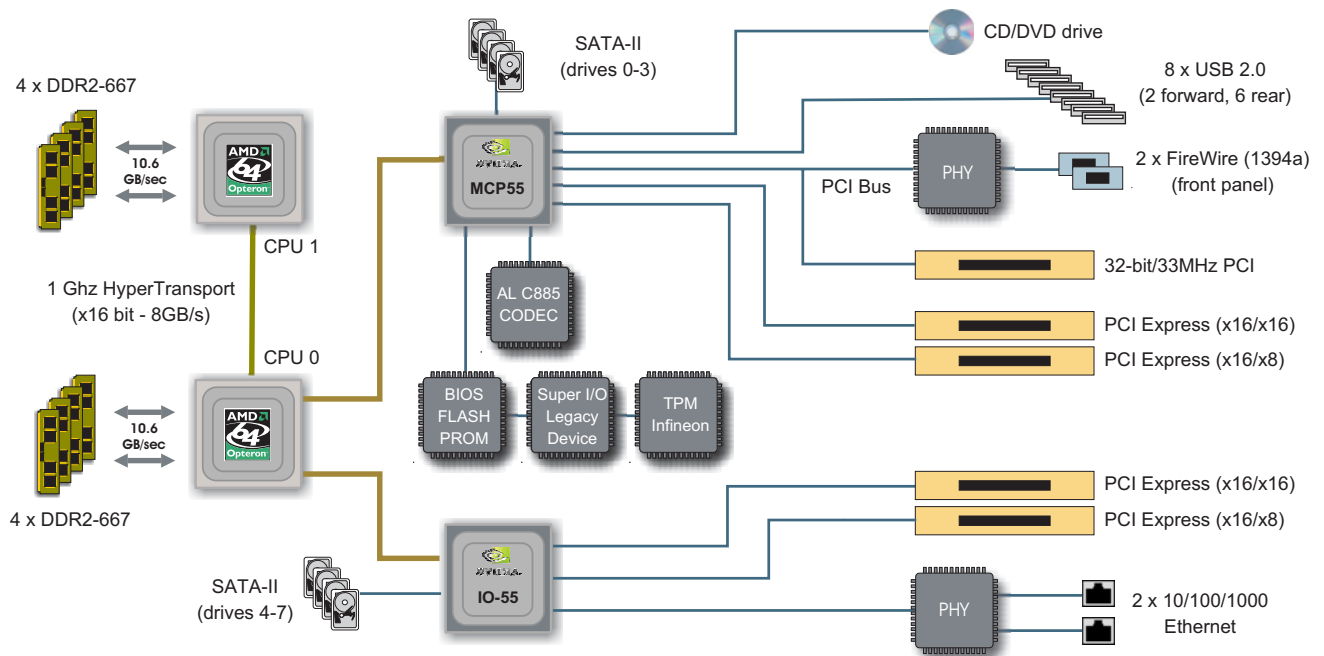

Figure 4. Sun Ultra 40 M2 workstation motherboard block-level diagram

Memory subsystem

The AMD Opteron 2200 Series processor's integrated DDR2 memory controller improves the way that typical x64 processors access main memory, resulting in increased bandwidth, reduced memory latencies, and increased processor performance. The dual-channel DDR2 memory controller on each processor is capable of yielding a memory bandwidth of 10.6 GB per second (two 5.3 GB per second channels) and supports up to four registered DDR2-667 DIMMs. Up to a maximum of 32 GB of memory is supported using four DIMM slots. 1 GB, 2 GB, and 4 GB DIMMs are available.

NVIDIA nForce Pro 3600 (MCP55) chipset

The AMD Opteron processor connects to an NVIDIA nForce Pro 3600 (MCP55) chipset via a 1 GHz HyperTransport connection. The Sun Ultra 40 M2 workstation utilizes the NVIDIA nForce Pro 3600 chipset to provide a wealth of system I/O. This revolutionary single-chip architecture enables full-featured motherboards, maximum performance, and low latency, along with lower levels of power consumption and heat dissipation. The first CPU (CPU 0) connects with the chipset across one of three integral 1 GHz HyperTransport links.

The NVIDIA nForce Pro 3600 chipset provides:

- Two dedicated PCI Express interfaces facilitating graphics accelerators and expansion boards (one x16 physical/x16 logical, one x16 physical/x8 logical)
- Two independent SATA 3.0 Gigabit per second controllers with Native Command Queuing and RAID support (RAID 0, 1, 0+1, 5, and JBOD) with each controller connected to two drives
- EIDE Controller, supporting up to ATA-133 for CD/DVD devices
- High Definition Audio (HDA), 1.0 compliant
- USB 2.0 ports
- I/O buses, including: PCI, LPC, SMBus, and APIC

It is important to note that the PCI Express slots on the Sun Ultra 40 M2 workstation are dedicated, and do not share bandwidth with each other, unlike some other systems. Each PCI Express slot in the Sun Ultra 40 workstation has access to its own dedicated connection and bandwidth to help ensure deterministic and predictable behavior for graphics accelerators and other PCI Express I/O options.

NVIDIA nForce Pro 3050 (IO-55) chipset

The NVIDIA nForce Pro 3050 (IO-55) chipset augments the I/O capabilities of the Sun Ultra 40 M2 workstation, connecting to CPU 0 via a second HyperTransport interconnect. The third HyperTransport interconnect connects to a second optional AMD Opteron 2200 Series processor (CPU 1). The NVIDIA nForce Pro 3050 chipset provides:

- Two dedicated PCI Express interfaces facilitating graphics accelerators and expansion boards (one x16 physical/x16 logical, one x16 physical/x8 logical)
- Dual IEEE 802.3 MACs for two 10/100/1000Base-T gigabit auto-negotiating Ethernet interfaces
- Two independent SATA 3.0 Gigabit per second controllers with Native Command Queuing and RAID support (RAID 0, 1, 0+1, and JBOD) with each controller connected to two drives

Mass Storage

Supported by both the NVIDIA nForce Pro 3600 and 3050 chipsets, each Sun Ultra 40 M2 workstation provides both ATA-133 support for optical media and a total of four independent SATA 3.0 (3 Gb per second) controllers for internal mass storage. One external drive bay and eight internal drive bays are included in the workstation chassis. The external drive bay is always occupied by either a 16x DVD Dual drive or DVD-ROM drive. The internal drive bays are occupied by up to eight hard disk drives. Standard configurations are available with a single drive, upgradeable to eight drives. The Sun Ultra 40 M2 workstation is also available in diskless configurations.

I/O ports, PCI, and PCI Express expansion slots

The Sun Ultra 40 M2 workstation provides a full complement of I/O and expansion capabilities. Figure 5 illustrates the front panel of the Sun Ultra 40 M2 workstation.

Features include:

- The slot-loading DVD-ROM plays DVD or CDs only (does not record) while the DVD-Dual drive records both CDs and DVDs.
- The LED shows the activity of the system.
- Two USB 2.0 ports and two IEEE 1394a (FireWire) ports are available on the front panel.
- Microphone and headphone connectors are provided for easy access.



Figure 5. Sun Ultra 40 M2 workstation front perspective, featuring two FireWire ports, two USB 2.0 ports, microphone, and headphone jacks (left to right) in addition to a DVD-ROM/CD-RW or DVD-Dual (DVD+/-RW, dual layer capable) drive

Figure 6 illustrates the back panel of the Sun Ultra 40 M2 workstation, containing:

- Audio connectors for audio out, audio in, and microphone in, center, side, back channels, as well as S/PDIF optical and coax in and out
- Two 10/10/1000BaseT gigabit Ethernet ports (RJ-45)
- Six USB 2.0 ports
- Four PCI Express expansion slots (two x16 physical/x16 logical, and two x16 physical/ x8 logical)
- A single PCI expansion slot (32-bit/33 MHz)

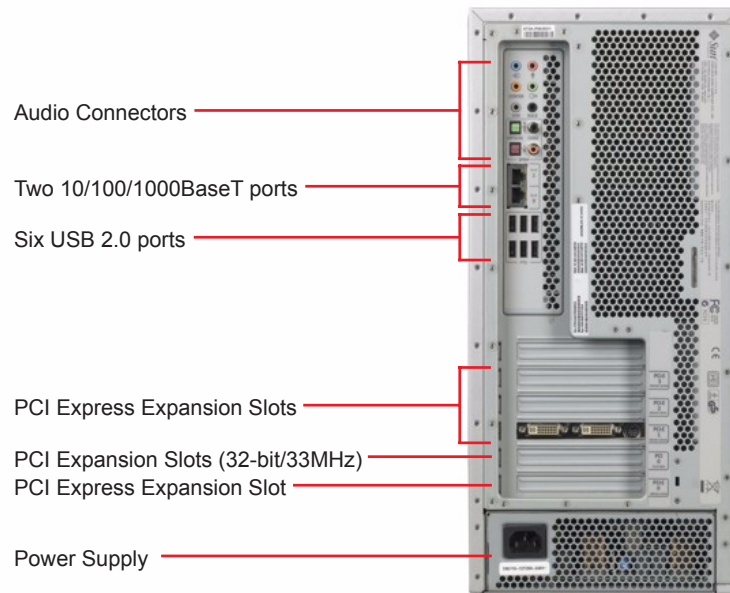

Figure 6. Sun Ultra 40 M2 workstation rear panel I/O connectors and expansion slots

Keyboard and Mouse

The Sun Ultra 40 M2 workstation comes standard with Sun Type-7 keyboard and mouse, and is fully validated with 27 different country kits to localize it to different countries and languages. The Type-7 keyboard is available in both UNIX and PC layouts, with different layout for non-standard keys such as ESC, Backspace, Caps Lock, and Control functions. The Sun Type-7 mouse provides three-button control with optical tracking and a scroll wheel. The optical sensor records motion more precisely than a traditional mouse for intricate point placement and adjustment, and no mouse pad is needed for this device.

Chapter 3

Innovative 2D and 3D Graphics and Visualization

With a broad range of uses, technical workstations must provide flexibility in terms of providing disparate requirements for graphics and visualization.

- Technical professionals require a range of different graphics solutions along with high-resolution, high-quality displays in order to learn, innovate, and drive shorter production cycles for faster time-to-market.
- Software developers need screen real estate and multiple display support but typically don't require 2D or 3D graphics acceleration.
- Electronic design professionals need 2D vector performance and visual clarity to inspect their layouts.
- Mechanical designers need the utmost in image quality and 3D acceleration to provide interactivity for demanding MCAD applications and to visualize the results of MCAE simulations.
- Scientists, researchers, and product designers need multi-display immersive visualization systems to interpret and understand their data
- Technical professionals from many disciplines need to share visual information and collaborate around large and complex datasets while getting the most from their investments.

In recent years, considerable consolidation has taken place in the computer graphics industry. Technological progress in terms of ASIC design and new interconnect standards such as PCI Express have enabled sophisticated feature sets and very high levels of performance to be compressed onto compact and high-performance graphics accelerators. Fortunately, this consolidation has meant that a wide variety of graphics solutions remain available to satisfy myriad professional needs.

While applications such as gaming now often drive the performance and functionality of graphics accelerators, companies such as NVIDIA provide a full line of solutions with certified quality for key professional applications. Coupled with the capabilities of the Sun Ultra 40 M2 workstation and new Sun Visualization System software, these solutions can provide a very wide array of graphics solutions to serve disparate needs.

Sun Ultra 40 system bandwidth and expansion

Sophisticated graphics accelerator technology requires significant system bandwidth in order to move large volumes of graphics primitives and ensure a high level of performance and interactivity. While some low-end accelerators support a single-lane x1 PCI Express connector, these are typically intended only as console graphics suitable for lower-level requirements (such as server consoles). Virtually all high-performance PCI Express graphics accelerators require a sixteen-lane x16 connector in order to gain the full benefits offered by PCI Express.

The Sun Ultra 40 M2 workstation is able to host a wide range of graphics solutions and visualization capabilities, supporting both multiple displays and multiple graphics accelerators. Coupled with support for powerful NVIDIA graphics solutions (Table 2), each system provides four dedicated x16 PCI Express slots.

Table 2. NVIDIA graphics solutions supported on the Sun Ultra 40 M2 workstation

	NVIDIA Quadro NVS 285	NVIDIA Quadro FX 560	NVIDIA Quadro FX 1500	NVIDIA Quadro FX 3500	NVIDIA Quadro FX 5500
Maximum accelerators supported	Four	Four	Four	Four	Two
Maximum displays	Eight	Eight	Eight	Eight	Four
Display connectors	59-pin DMS-59 connector (with DMS-59 to DVI cable)	Dual Link DVI, Single Link DVI, 7-pin mini-DIN HDTV-out connector	2 Dual-Link DVI, 7-pin mini-DIN HDTV-out connector	2 Dual Link DVI, 3-pin mini stereo-out connector	2 Dual-Link DVI, 3-pin mini-stereo-out connector
Maximum resolution (digital)	1920 x 1200	3840 x 2400 @ 24 Hz	3840 x 2400 @ 24 Hz	3840 x 2400 @ 24 Hz	3840 x 2400 @ 24 Hz
Maximum resolution (analog)	2048 x 1536 @ 75 Hz	2048 x 1536 @ 75 Hz	2048 x 1536 @ 75 Hz	2048 x 1536 @ 75 Hz	2048 x 1536 @ 75 Hz
Sun display support	24.1-inch LCD, 20-inch LCD, 19-inch LCD, 17-inch CRT ^a				

a.Third-party displays required to support some maximum resolutions

Industry-leading NVIDIA graphics solutions

Supported NVIDIA graphics solutions are described in the sections that follow.

NVIDIA Quadro NVS 285 graphics

The NVIDIA Quadro NVS 285 graphics solution provides Sun Ultra 40 M2 workstation customers with high-quality professional 2D workstation graphics for software development and EDA applications. Implemented as a x16 PCI Express graphics card, the NVIDIA Quadro NVS 285 can drive dual digital displays at resolutions up to 1920 x 1200 with the included DMS59 to DVI cable (Figure 7). Each NVIDIA Quadro NVS graphics card can also drive up to two analog displays via an optional DVI-to-VGA adapter.



Figure 7. NVIDIA Quadro NVS 285 graphics card, back panel, and DMS59 to DVI adapter cable

Table 3 lists the capabilities of the NVIDIA Quadro NVS 285 graphics solution.

Table 3. NVIDIA Quadro NVS 285 graphics properties

Capability	Description
Form factor	PCI Express x16, low profile printed circuit board with full-height connector
Memory	128MB of DDR2 SDRAM (64-bit interface)
Memory clock	300 MHz
Graphics clock	276 MHz
Connector	59 pin DMS-59 connector and DMS-59 connector-to-DVI cable
Display support	Digital display at resolutions up to 1920 x 1200 Analog display at resolutions up to 2048 x 1536 @ 75 Hz
Available drivers	Solaris 10, Red Hat Enterprise Linux WS 3 and 4 (32-bit and 64-bit), SuSE Linux Enterprise Desktop 10 (64-bit), Windows XP Professional (32-bit and 64-bit)

NVIDIA Quadro FX 560 graphics

The NVIDIA Quadro FX 560 graphics solution (Figure 8) features uncompromised performance and programmability for an entry-level 3D accelerator. With advanced features ranging from a 128-bit floating point graphics pipeline, 12-bit sub-pixel precision, fast GDDR3 memory, and HDTV output, the NVIDIA Quadro FX 560 graphics solution is certified for a wide set of CAD, DCC, and visualization applications. In addition, support for one dual-link DVI output and HDTV component output facilitates direct connection to both high resolution digital flat panels and broadcast monitors, ideal for video editing applications.

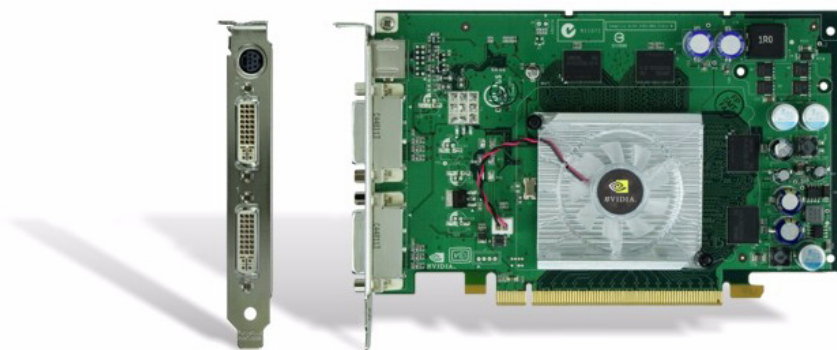

Figure 8. NVIDIA Quadro FX 560 graphics card and back panel

Each NVIDIA Quadro FX 560 graphics card provides one Dual Link and one Single Link DVI-I output. The Single Link DVI-I output can drive digital displays at resolutions up to 1900 x 1200 @ 60 Hz. The Dual Link DVI-I connector can drive resolutions up to 3840 x 2400 @ 24Hz. Dual internal 400MHz RAMDACs enable support for two analog displays at up to 2048 x 1536 @ 75Hz with an optional DVI-to-VGA adapter (Sun Part Number X8015A). Table 4 lists the properties of the NVIDIA Quadro FX 560 graphics solution.

Table 4. NVIDIA Quadro FX 560 graphics properties

Capability	Description
Form factor	PCI Express x16, full-height printed circuit board
Memory	128 MB of GDDR3 SDRAM (256-bit interface)
Clock rates	300 MHz memory clock, 350 MHz graphics clock
Connectors	Primary connector: Dual-Link DVI-I (digital) Secondary connector: Single-Link DVI-I (digital) 7-pin mini-DIN HDTV-out connector
Display support	Dual-Link DVI-I: Drives a digital display at resolutions up to 3840 x 2400 @ 24 Hz Single-Link DVI-I: Digital display at resolutions up to 1920 x 1200 x 32 bpp @ 60 Hz with reduced blanking Dual internal 400 MHz RAMDACs for analog resolutions up to 2048 x 1536 @ 75 Hz
Available drivers	Solaris 10, Red Hat Enterprise Linux WS 3 and 4 (32-bit and 64-bit), SuSE Linux Enterprise Desktop 10 (64-bit), Windows XP Professional (32-bit and 64-bit)

NVIDIA Quadro FX 1500 graphics

Combined with the Sun Ultra 40 M2 workstation, the NVIDIA Quadro FX 1500 graphics solution (Figure 9) provides an effective mid-range graphics workstation that delivers unprecedented price/performance. The revolutionary new architecture of the accelerator increases raw geometry and fill rate performance over previous-generation products, and delivers 40 GB per second of memory bandwidth with support for 256 MB of ultra-fast GDDR3 memory. The NVIDIA Quadro FX 1500 graphics card provides an optimal blend of quality, precision, performance, programmability, and price for all professional CAD, DCC, and visualization applications.

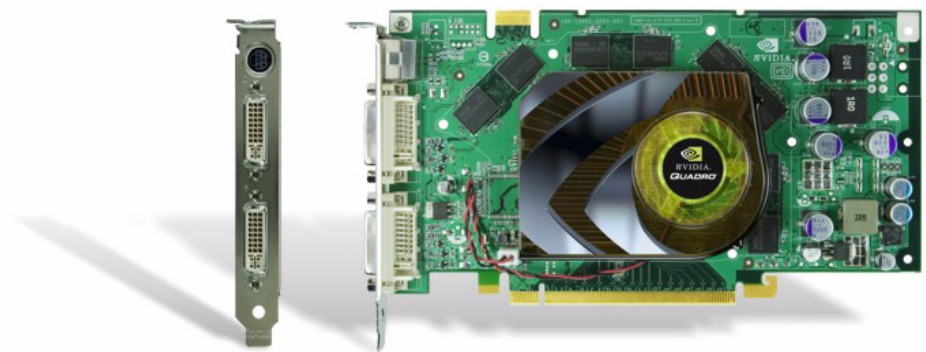

Figure 9. NVIDIA Quadro FX 1500 graphics card and back panel.

Featuring HDTV out and two Dual-Link DVI-I connectors, the NVIDIA Quadro FX 1500 offers the industry's best image quality at digital resolutions up to 3840 x 2400. High-resolution antialiasing is provided with 12-bit sub-pixel sampling precision and Rotated Grid Full-Scene Antialiasing to reduce visual aliasing artifacts at resolutions up to 1920 x 1200. Table 5 lists the properties of the NVIDIA Quadro FX 1500 graphics solution.

Table 5. NVIDIA Quadro FX 1500 graphics properties

Capability	Description
Form factor	PCI Express x16, full-height printed circuit board
Memory	256 MB of GDDR3 SDRAM (256-bit interface)
Clock rates	625 MHz memory clock, 325 MHz graphics clock
Connectors	Two Dual-Link DVI-I (digital) connectors 7-pin mini-DIN HDTV-out connector
Display support	Two Dual-Link DVI-I: Drives digital displays at resolutions up to 3840 x 2400 @ 24 Hz Analog display output: Drives an analog display at resolutions up to 2048 x 1536 @ 75 Hz Dual internal 400 MHz RAMDACs
Available drivers	Solaris 10, Red Hat Enterprise Linux WS 3 and 4 (32-bit and 64-bit), SuSE Linux Enterprise Desktop 10 (64-bit), Windows XP Professional (32-bit and 64-bit)

NVIDIA Quadro FX 3500 graphics

The NVIDIA Quadro FX 3500 graphics solution (Figure 10) offers a new level of interactivity for engineers and designers, helping to enable the ultimate in performance, features, and quality. With these goals in mind, the NVIDIA Quadro FX 3500 graphics solution delivers 42.2 GB per second memory bandwidth and a 256-bit memory interface with support for 256 MB of ultra-fast GDDR3 memory. The NVIDIA Quadro FX 3500 graphics card also supports stereoscopic video output through a 3-pin DIN connector, used to carry a synch signal to stereo shutter glasses and other stereo devices.



Figure 10. NVIDIA Quadro FX 3500 graphics card and back panel

Table 6 lists the properties of the NVIDIA Quadro FX 3500 graphics solution

Table 6. NVIDIA Quadro FX 3500 graphics properties

Capability	Description
Form factor	PCI Express x16, full-height printed circuit board
Memory	256 MB of GDDR3 SDRAM (256-bit interface)
Clock rates	600 MHz memory clock, 450 MHz graphics clock
Connectors	Two Dual-Link DVI-I (digital) connectors 3-pin stereo sync via DIN connector
Display support	Dual-Link DVI-I: Drives a digital display at resolutions up to 3840 x 2400 @ 24 Hz Analog display output: Drives an analog display at resolutions up to 2048 x 1536 @ 75 Hz Dual internal 400 MHz RAMDACs
Available drivers	Solaris 10, Red Hat Enterprise Linux WS 3 and 4 (32-bit and 64-bit), SuSE Linux Enterprise Desktop (64-bit), Windows XP Professional (32-bit and 64-bit)

NVIDIA Quadro FX 5500 graphics

The NVIDIA Quadro FX 5500 graphics solution is an ultra high-end 3D graphics card with dual display capability, ideal for CAD, DCC, and visualization applications. Armed with a radically new graphics architecture engineered to address the most demanding challenges, the NVIDIA Quadro FX 5500 delivers 33.6 GB/sec. memory bandwidth and a 256-bit memory interface, with support for 1024 MB of ultra-fast GDDR2 memory. Featuring two dual-link DVI connectors, the NVIDIA Quadro FX 5500 offers some of the industry's best image quality at resolutions up to 3840 x 2400. The Sun Ultra 40 M2 workstation supports up to two NVIDIA Quadro FX 5500 graphics card with NVIDIA SLI technology.



Figure 11. NVIDIA Quadro FX 5500 graphics card and back panel

Table 6 lists the properties of the NVIDIA Quadro FX 5500 graphics solution

Table 7. NVIDIA Quadro FX 5500 graphics properties

Capability	Description
Form factor	PCI Express x16, full-height double-wide printed circuit board
Memory	1 GB of ultra-fast GDDR2 SDRAM (256-bit interface)
Connectors	Two Dual-Link DVI-I (digital) connectors 3-pin stereo sync via DIN connector
Display support	Dual-Link DVI-I: Drives a digital display at resolutions up to 3840 x 2400 @ 24 Hz Analog display output: Drives an analog display at resolutions up to 2048 x 1536 @ 75 Hz Dual internal 400 MHz RAMDACs
Available drivers	Solaris 10, Red Hat Enterprise Linux WS 3 and 4 (32-bit and 64-bit), SuSE Linux Enterprise Server 9 (32-bit and 64-bit), Windows XP Professional (32-bit and 64-bit)

Display Options

Technical professionals need a choice of bright, clear displays to help them visualize their projects and designs. Sun provides a variety of displays that are fully validated to work with the Sun Ultra 40 M2 workstation and its supported graphics accelerators. Table 8 lists supported Sun displays as of this writing.

Table 8. Displays supported on the Sun Ultra 40 M2 workstation

	Sun 24.1-inch LCD Display	Sun 20.1-inch LCD Display	Sun 19-inch LCD Display	Sun 17-inch LCD Display
Resolutions	1920 x 1200	1600 x 1200	1280 x 1024	1280 x 1024
Pixel pitch	0.27m	0.255m	0.294m	0.264m
Contrast ratio	1000:1	700:1	350:1	500:1
Inputs	DVI-D (digital) HD-15 (analog) YpbPr (component) S-Video C-Video	DVI-D (digital) HD-15 (analog)	DVI-D (digital) HD-15 (analog)	DVI-D (digital) HD-15 (analog)

Note – Third party displays are required to support the maximum resolutions of some supported NVIDIA graphics solutions.

The Sun Visualization System

Beyond the capabilities of individual systems and graphics accelerators, multi-display visualization systems are playing an increasingly important role in letting researchers, scientists, and designers see beyond their data for better interpretation and analysis. To address these needs, the Sun Visualization System delivers scalable, sharable, and affordable immersive and remote collaboration visualization solutions that can be

easily integrated into existing IT infrastructure. When built by Sun's Customer Ready Systems (CRS) program, these customizable solutions can help take the complexity and risk out of designing and deploying visualization technology. A high level of integration along with innovative software solutions means that organizations can concentrate on solving their most challenging problems, rather than on designing and configuring complicated visualization infrastructure.

Sun Scalable Visualization software

Sun Scalable Visualization software can use high-bandwidth, low-latency interconnects such as InfiniBand to expand visualization clusters beyond the capabilities of individual systems. Sun Scalable Visualization software supports the combination of multiple graphics pipelines to drive performance, image quality, and resolution for diverse needs. For example, multiple Sun Ultra 40 M2 workstations, each with multiple NVIDIA graphics cards, could be combined into a multi-display visualization system.

Sun Shared Visualization software

Just as important as the ability to scale, is the ability to collaborate and share. Sun Shared Visualization software lets organizations share compute and graphics resources remotely, aiding collaboration and security, and lowering total cost of ownership. Integration with Sun N1 Grid Engine software means that visualization resources become schedulable and sharable, providing easy access combined with centralized management and better utilization. Sun Shared and Scalable Visualization software can also be combined in the same Sun Visualization System.

Note – As of this writing, the Sun Visualization System, including Sun Scalable Visualization software and Sun Shared Visualization software are in a technology preview stage. For the latest Sun visualization offerings, please visit: <http://www.sun.com/hpc/visualization>

Chapter 4

Operating Systems, Grid Software, and Development Tools

Technical professional need the flexibility to make decisions that are right for their applications and their own priorities, even as their needs continue to change. Being able to choose and deploy multiple operating systems as a user or developer is increasingly important. Collaboration and utilization of computational resources (and even graphical resources) is getting more attention. Getting to the best application performance, whether on as a user or developer, also requires proven platforms and tools. With a wide choice of certified operating systems, unique Solaris 10 features, a free Sun N1 Grid Engine license, and wealth of pre-installed development tools, the Sun Ultra 40 M2 workstation provides an ideal solution.

A choice of operating systems

Designers, engineers, and scientists need to run the right applications for their most critical tasks, and those applications are not always available on the desired operating system. Developers also need to be able to develop and test for multiple operating systems without engaging multiple external systems or compromising their own personal productivity environments. Fortunately, Sun the Ultra 20 M2 workstation is certified to run a wide range of operating systems, providing considerable flexibility and choice. The operating systems supported as of this writing include:

- The Solaris 10 Operating System with support for Solaris Containers (Solaris 10 OS for x64 6/06 and later)
- Red Hat Enterprise Linux WS 3 (32-bit and 64-bit) Update 8 and later
- Red Hat Enterprise Linux WS 4 (32-bit and 64-bit) Update 4 and later
- SuSE Linux Enterprise Desktop 10 (64-bit version)
- Microsoft Windows XP Professional (std. and x64 Edition) Service Pack 2 and later

For the latest supported operating systems, please see <http://sun.com/x64>.

Not only can all of these environments be installed on the Sun Ultra 40 M2 workstation, but multi-boot configurations can be built that allow a single system to boot into any of these environments on demand. In addition, emerging virtualization environments can provide simultaneous access to multiple main and guest operating systems.

Solaris™ 10 OS Support for Flexibility and Enhanced Performance

Among the available operating systems, the Solaris OS provides a stable, reliable, and high performance platform that lets users develop, test, and deploy their most important applications. The Solaris 10 OS is pre-configured by default on each Sun Ultra 40 M2 workstation. The Solaris OS is ideal for large-scale enterprise deployments, and

has features that can enhance the flexibility and performance of workstations in their roles as application and development platforms.

- ***Solaris Containers for consolidation, secure partitioning, and virtualization***

With the advancing performance profiles of technical workstations, both designers and developers often want to utilize their systems to the fullest, without compromising their main productivity environments. For instance, a mechanical designer might want to run an MCAE simulation on his desktop system without compromising on-going MCAD performance. An electronic design professional might likewise wish to run several verifications, simulations, regressions on a design in progress. In a similar vein, a software designer might want to test complex distributed software that typically communicates between multiple networked systems.

Solaris Containers provide an effective and compelling solution for all of these challenges, helping to efficiently manage system resources, virtualize the system, and provide a complete, isolated, and secure runtime environment for applications. Solaris Containers are comprised of a group of technologies that work together, including Solaris Zones, Solaris Resource Management, and the Solaris fair-share scheduler. Often used in server configurations, Solaris Containers can also be used to partition and allocate the computational resources of the Sun Ultra 40 M2 workstation. Solaris Zones enable an administrator to create multiple separate environments for applications on a single system, while the resource management framework allows for the allocation, management, and accounting of system resources such as CPU and memory.

- Solaris Zones — Solaris Zones can be used to create an isolated and secure environment for running applications. A zone is a virtualized operating system environment created within a single instance of the Solaris OS. Zones can be used to isolate applications and processes from the rest of the system. This isolation helps enhance security and reliability since processes in one zone are prevented from interfering with processes running in another zone.
- Resource Management — Resource management tools provided with the Solaris OS help enable system resources such as CPU cycles to be dedicated to specific applications. CPUs in a multi-core system such as the Sun Ultra 40 M2 workstation can be logically partitioned into processor sets and bound to a resource pool, which in turn can be assigned to a Solaris zone. Resource pools provide the capability to separate workloads so that consumption of CPU resources does not overlap, and also provides a persistent configuration mechanism for processor sets and scheduling class assignment. In addition, the dynamic features of resource pools let administrators adjust system resources in response to changing workload demands.

- ***Solaris Dynamic Tracing (DTtrace) to instrument and tune live software environments***

When production systems exhibit nonfatal errors or sub-par performance, the sheer complexity of modern distributed software environments can make accurate root-cause diagnosis extremely difficult. Developers and designers both need to be able to resolve root-cause performance issues that impact applications under use, development, or test. Unfortunately, most traditional approaches to solving this problem have proved time-consuming and inadequate, leaving many applications languishing far from their potential performance levels.

The Solaris DTrace facility provides dynamic instrumentation and tracing for both application and kernel activities — even allowing tracing of application components running in a Java Virtual Machine (JVM™)¹. DTrace enables developers and administrators to explore the entire system to understand how it works, track down performance problems across many layers of software, or locate the cause of aberrant behavior. Tracing is accomplished by dynamically modifying the operating system kernel to record additional data at locations of interest. Best of all, although DTrace is always available and ready to use, it has no impact on system performance when not in use, making it particularly effective for monitoring and analyzing production systems.

Sun N1™ Grid Engine software

High powered technical systems such as the Sun Ultra 40 M2 workstation provide considerable computational and visual resources for their primary users. With support for up to two dual-core AMD Opteron processors, up to 32 GB of memory, multiple NVIDIA graphics accelerators, and up to four terabytes of storage, those resources can be significant. For these reasons, each Sun Ultra 40 M2 workstation ships with a free license for Sun N1 Grid Engine software, allowing the effective sharing of desktop resources when they are not needed by their primary user.

Sun N1 Grid Engine 6 distributed resource management (DRM) software provides job scheduling and policy automation, unifying network-connected servers, workstations, and desktops while providing user access to the grid along with essential administrative and management interfaces. Computing tasks or jobs are distributed across the grid in accordance with resource requirements for the job, user requests for the job, and administrative and managerial policies. Usage accounting data is stored and made available so that it is possible to determine what resources were used in the execution of a job and for whom the job was run. Sun N1 Grid Engine 6 administrative overhead is quite low, letting overall resource utilization approach 100 percent (depending upon the optimization of resources to the workload).

Sun N1 Grid Engine software is used to create grids at both a department level and at a multi-department or enterprise level. Through the pooling of departmental

1. The terms “Java Virtual Machine” and “JVM” mean a Virtual Machine for the Java platform.

resources into larger enterprise grids, multiple users, teams, and departments can share common resources while working on different projects with different goals and schedules, providing maximum resource availability to all users in a flexible, policy-based environment. Grid Engine software also offers heterogeneous support, enabling grids to be built from a wide variety of hardware systems and operating environments and spreading the benefits of grid computing across the entire IT infrastructure.

Pre-installed Sun software development tools

To provide an effective development system right out of the box, each Sun Ultra 20 M2 workstation ships with a wealth of development tools pre-installed, including those listed in this section.

Sun Java™ Studio Creator

Award-winning Sun Java Studio Creator software helps enable rapid and visual web application development on the Java Platform. Using Java Studio Creator, developers can quickly develop standards-based web applications and portlets in a powerful drag-and-drop environment using JavaServer™ Faces components. Sun Java Studio Creator includes major enhancements, including a comprehensive library of new JavaServer Faces components, support for portlet development, refactoring, integration with version control systems, enhanced data access and application models, and many other features. Java Studio Creator extends NetBeans by adding a visual drag-and-drop environment. The Java Developer's Kit (JDK™), Sun Java System Application Server 8.1 Platform Edition, and sample database are all pre-configured as well.

Sun Studio Compilers and Tools

Sun Studio provides developers with the latest record-setting, high-performance, optimizing C, C++, and FORTRAN compiler compilers for the Solaris OS on SPARC and x86/x64 platforms. Command-line tools and a NetBeans-based Integrated Development Environment (IDE) are provided for application performance analysis and debugging of mixed source language applications. In addition to providing multi-platform support, Sun Studio compilers are compatible with gcc, Visual C++, C99, OpenMP, and FORTRAN 2003.

Sun Java Studio Enterprise

The Sun Java Studio Enterprise IDE is an award-winning development platform that provides powerful features to speed development, including UML modeling, instant collaboration, and application profiling. The IDE is also fully integrated with a complete the Sun Java Enterprise System run-time environment. Built on the popular NetBeans IDE, Sun Java Studio Enterprise offers all of the functionality needed to develop, debut,

tune, and deploy enterprise applications, web services, and portal components based on the Java Platform Enterprise Edition (Java EE platform).

NetBeans™ IDE

The NetBeans IDE offers comprehensive support for building IDE plug-in modules and rich client applications on the NetBeans platform. Many NetBeans features help maximize productivity and flexibility for building robust, standards-compliant Java applications. In addition, multiple add-on packs can be added to the base NetBeans distribution to help developers build specific kinds of applications. For example, the NetBeans Enterprise Pack supports development of Java EE 5 enterprise applications and includes Service Oriented Architecture (SOA) visual design tools, XML schema tools, web services orchestration (for BPEL), and UML modeling. The NetBeans Mobility pack helps developers write, test, and debug applications for Java Platform Micro Edition (Java ME platform) technology enabled mobile devices.

Chapter 5

Conclusion

Performance, value, flexibility, and innovation are all key for today's scientists, researchers, designers, and engineers as they seek to describe, visualize, and explore their data and bring new products to market. With so much riding on new discoveries that result in new scientific insights as well as effective, safe, and timely products, these professionals need the very best tools they can obtain. Ultimately, designing workstation products for these demanding technical professionals requires an approach that goes beyond cheap PC components, or even the latest hot box or processor. With vast experience in the technical workstation marketplace, Sun is uniquely positioned to bring its considerable expertise to advance x64 technology. The result is credible and capable workstation technology that helps drive performance and productivity for a host of demanding applications and datasets.

The Sun Ultra 40 M2 workstation combines careful design and integration with the very latest Next-Generation AMD Opteron 2200 Processors, large memory support, multiple terabytes of storage, and a full range of 2D and 3D NVIDIA graphics solutions. With a choice of operating systems including the Solaris OS, Linux, and Microsoft Windows, these systems are truly flexible and appropriate for a wide variety of technical applications. Pre-loaded with the feature-rich Solaris 10 OS and a wealth of development tools, and licensed for Sun N1 Grid Engine software, Sun Ultra 40 M2 workstations are ready to go to work as soon as they are unpacked.

Conclusion

Sun Microsystems, Inc. 4150 Network Circle, Santa Clara, CA 95054 USA **Phone** 1-650-960-1300 or 1-800-555-9SUN (9786) **Web** sun.com

© 2006 Sun Microsystems, Inc. All rights reserved. Sun, Sun Microsystems, the Sun logo, Java, Java Server, JDK, JVM, NetBeans, N1, Solaris, and Sun Ultra are trademarks or registered trademarks of Sun Microsystems, Inc. in the United States and other countries. AMD, Opteron, and the Opteron logo are trademarks or registered trademarks of Advanced Micro Devices, Inc. Information subject to change without notice.



Printed in USA 11/06